

Pacific Dental Conference

March 4-6, 2027

Vancouver Convention Centre -
West and East Buildings



Exhibitor Prospectus



Request booth space at...
pacificdentalconference.com

Prospectus updated as of June 1

Table of Contents

PDC Exhibit Hall open March 4-5

Invitation to Exhibit	2	Event Rules and Regulations	10
Attendance Statistics	2	Booth Representative Registration	10
Important 2027 PDC Dates and Deadlines	3	Booth Supply Orders	11
Booth Purchasing Process	4, 5	Health and Safety Protocols	11
Booth Pricing	4	Move In / Move Out Procedures	12-14
Booth Guidelines	6	Hotel Information	15
Booth Design	6, 7	2026 PDC Exhibitors	16-17
Exhibitor Rules of Conduct	8, 9	Future Dates	20
Exhibitor Compliance Requirements	9		



More information available at...

www.pacificdentalconference.com

The 2027 Pacific Dental Conference will be held at the Vancouver Convention Centre. We're excited to see the consistent growth of the conference over the past years with **13,945 participants** at the 2026 PDC (in-person). Partnering with valued exhibitors such as yourself is important to our continued success.

Pacific Dental Conference Attendance Statistics 2016 to 2026

	2016*	2017	2018	2019	2020	2021**	2022**	2023	2024*	2025	2026
Dentists	3643	3831	3975	4026	4207	3531	3514	4222	4250	4347	4330
Dental Hygienists	1964	2109	2125	2189	2393	2853	1807	2572	2539	2600	2390
Dental Assistants	2500	2643	2759	2684	2866	2541	1823	3004	2910	2855	2622
Adm. Personnel	650	687	750	753	819	206	127	831	758	800	858
Dental Technicians	261	281	303	324	292	218	220	252	236	239	232
Denturists	68	69	82	79	66	60	58	57	64	60	61
Dental Therapists	47	37	51	63	39	23	21	42	29	27	32
Exhibits Only	492	514	504	500	477	0	0	532	375	408	157
Students	572	609	647	608	655	235	165	653	770	663	516
Other	314	265	302	335	346	78	29	335	394	350	336
Exhibitors	2444	2565	2517	2606	2592	773	297	2353	2530	2412	2411
PDC Lab Expo Exhibitors					112	109	93	0	0	0	0
Total	12,955	13,610	14,127	14,276	14,845	10,518	8,061	14,853	14,855	14,761	13,945

*in conjunction with the Canadian Dental Association

**virtual conference (only)

Important 2027 PDC Dates and Deadlines

June 1, 2026

- Website open www.pacificdentalconference.com.

August 25, 2026

- Hotel reservations open.

September 15, 2026 9am PDT

TIER 1 - Booth Purchasing open
Four booths (20x20) Three booths (10x30)
(full payment required) More details on pages 4-5

September 29, 2026

- Final date for Tier 1 booth purchases.

October 6, 2026

- Move In floorplan available on website.

October 6, 2026 9am PDT

TIER 2 - Booth Purchasing opening
Two booths (10x20) purchases open
(full payment required) More details on pages 4-5

October 20, 2026

- Final date for Tier 2 booth purchases.

October 28, 2026

- Final date for booth cancellations.
No refunds will be issued after this date.

October 29, 2026 9am PDT

TIER 3 - Booth Purchasing open
Single booth (10x10)
(full payment required) More details on pages 4-5

December 1, 2026

- Show Service Forms available on website.

January 17, 2027

- All booth variation requests due.

March 2, 2027

- Move In as per pre-arranged schedule.

March 3, 2027

- Move In as per pre-arranged schedule.
- On-site Exhibitor Badge Printing open 7:00am to 7:00pm.

March 4 & 5, 2027

- On-site Exhibitor Badge Printing open 7:00am to 6:00pm.
- Hall opens at 7:00am each day for booth set-up to exhibitor name badges required
- Exhibit Hall open 8:30am - 5:30pm.

Friday, March 5, 2027

- Move Out starts at 5:30pm.



Inquiries

Pacific Dental Conference (office)
420 - 4400 Dominion Street
Burnaby, BC V5G 4G3

Telephone: 604-736-3781
exhibits@pdconf.com

www.pacificdentalconference.com for Exhibitors Section

Exhibit Location

Vancouver Convention Centre - West Building
1055 Canada Place Vancouver, BC V6C 0C3

NEW Booth Purchasing Process

The Pacific Dental Conference is introducing a new direct-to-book sales process for 2027. Booths will be sold through a 3-tiered process based on the number of booths (size of footprint) purchased. This updated process allows exhibitors to directly purchase their preferred booth location, providing immediate booth confirmation and allowing exhibitors to secure space as soon as their eligible sales stage opens. **There will be no requests and assignments as in the past.**

Within each purchasing tier, booth locations will be available on a first come, first served basis. Exhibitors purchasing larger booth footprints will receive earlier access to booth selection opportunities. Once a tier opens, exhibitors within that tier may choose from all the currently available booth locations and configurations at the time of purchase. Booth configurations will be updated to accommodate each tier requirements.

Returning Exhibitors from 2026

Companies who exhibited in 2026 will **receive a booking code** emailed to access our website in order for your company information to be pre-populated and make their purchase. **Please ensure your company contact information is current.**

New Exhibitors

When purchasing your booth you will be asked to provide **company name, address and contact details for the primary person** prior to accessing the floor plan to select their booth. Once your booth has been purchased, you will receive access to the **Exhibitor Resource Centre**, where you can log in and provide all additional company and booth information.

Booth Purchase Procedure

Booth space for the conference will be sold through a 3-tiered purchasing process based on the number of booths (footprint size) purchased. **Payment in full (100%)** will be required at time of purchase to secure the booth location.

TIER 1 – Booth Purchasing

- Four (4) booths — 20' x 20' footprint, or
 - Three (3) booths — 10' x 30' footprint
- will have access to the website starting **September 15, 2026, at 9 AM** until **September 29, 2026**

Full payment required

TIER 2 – Booth Purchasing

- Two (2) booths — 10' x 20' footprint
- will have purchase opportunities following completion of Tier 1 purchasing, starting **October 6, 2026, at 9 AM** until **October 20, 2026**

Full payment required





TIER 3 – Booth Purchasing

- One (1) booth — 10' x 10' footprint
- Single booth sales will open **Thursday October 29, 2026, at 9 AM.**
Single booth sales will remain open until all booths are sold.

Full payment required

Booth Prices

Please view the interactive floor plan at pacificdentalconference.com. All booths will be colour coded indicating their type and price.

-  **Premium Booth** – is 10' x 10'. Cost of booths are **\$3,800.00 plus GST**
-  **Deluxe Corner Booth** – is 10' x 10'. Cost of booths are **\$3,700.00 plus GST**
-  **Deluxe Booth** – is 10' x 10'. Cost of booths are **\$3,500.00 plus GST**
-  **Standard Booth** – is 10' x 10'. Cost of booths are **\$2,300.00 plus GST**

Booth prices are the same as 2026.

NEW Booth Purchasing Process

Payment Requirements

All booth purchases must be **paid in full** (100%) at the time of purchase in order to secure the selected booth location. Locations are not considered confirmed or reserved until full payment has been received.

Accepted Payment Methods

Payments may be made online using:

- VISA
- MasterCard
- American Express (Amex)



Booth Purchasing Rules

- Booth locations are selected and directly purchased by exhibitors during their designated purchasing tier.
- Booth selection is available on a first come, first served basis within each tier.
- Booth locations cannot be held without full payment.
- Exhibitors may only purchase booth quantities that correspond to the tier for which they are eligible at the time of purchase.
- Booth sharing, transferring or subletting is **not permitted**.
- Conference organizers reserve the right to adjust booth locations if required due to venue, safety, operational, or floorplan considerations. Should a relocation be necessary, organizers will make reasonable efforts to provide a comparable booth location and footprint.

Cancellation and Refund Policy

- All cancellation requests must be submitted in writing to exhibits@pdconf.com.
- Please note that booth footprint **cannot be downsized** after purchasing.
- Cancellations between the purchase date and **October 28, 2026** - **50% refund**.
- Cancellations received after **October 28, 2026**, - **No refunds will be issued**.

Additional Cancellation Terms

- Failure to occupy a purchased booth space does not qualify for a refund.
- Refunds, when approved, will be processed to the original method of payment.
- If the conference is postponed, booth purchases will be transferred to the rescheduled event date.
- In the event the conference must be cancelled by the organizers, exhibitors will be notified of refund or credit options as determined by the organizing committee.

Exhibition Move In and Set Up Times

Booth Move In times are designated according to booth location in the Exhibit Hall. Exhibitors will receive the booth Move In schedule/floor plan with their booth confirmation and it will be available on the website as of **Tuesday, October 6, 2026**. Exhibitor badges are mandatory as of **Wednesday, March 3, 2027** and all exhibitors and set-up personnel must wear their exhibitor badge to gain entry to the Exhibit Hall. **Safety vests are mandatory in the Exhibit Hall during Move In and Move Out, and can be purchased through onsite vending machines at the Convention Centre.**

Contract/Labour personnel are required to have Set Up Badge for Exhibit Hall entrance. Must show ID and sign in with the company they are setting up. See PDC Info Desk.

All displays must be in assigned areas, completed and ready for inspection, by **8:00am on Thursday, March 4, 2027**. No display material, except hand-carried, may be moved through the exhibit area after the show's opening. In the event an exhibitor fails to set up within the specified time, their property may be removed and stored at the sole expense of the exhibitor. (See page 12)

Dismantling Time

No booth may be dismantled earlier than **5:30pm, Friday, March 5, 2027**. All exhibit material must be packed and removed from the exhibit floor by **3:00pm on Saturday, March 6, 2027**, unless previous arrangements have been made. (See page 12)

Floorplan Availability

In order to facilitate your booking of hotels and flights, the Move In floorplan will be available on the website as of **October 6, 2026**.

Booth Guidelines

Booth Rental Includes:

- A pipe and drape 8 foot back wall and 3 foot side wall of drape
- Overnight security in the exhibit area
- Daily cleaning of common areas and aisles
- Access to exhibitor lounge and refreshments
- Company listing and contact information in final program
- Company listing on PDC website
- Company listing and location on PDC App

Booth Rental Does Not Include:

- Carpeting/flooring, tables or chairs
(Carpeting/flooring is mandatory and must be ordered through Levy Show Services or supplied by the exhibitor)
- Movement, transfer, removal, storage, setup and dismantling of the booth contents
- Cleaning of the booth
- Electrical requirements
- Internet connection

*Show service forms and online ordering will be available on the website, as of December 1, 2026 at www.pacificdentalconference.com

Booth Design

Booth and Display Structure Regulations

For any booths which do not conform to the design regulations, written approval of the variation must be obtained from the Pacific Dental Conference by **January 17, 2027**.

A. Single Aisle Booth

- Booths which face the numbered aisles must conform to the requirements of a single aisle booth.
- The back wall of the booth shall not exceed 12 feet in height.
- No sidewalls, fixtures, or other display materials shall extend higher than 4 feet from floor level for the first 5 feet from the aisle. Beyond this limit, the sidewalls can extend to 12 feet in height.
- Products designed to stand on the floor may extend higher than this limit, but must be positioned as close to the back wall as possible to avoid blocking the view of the adjacent exhibitor.
- Signs and booth decor (including balloons) may not exceed 12 feet in height.

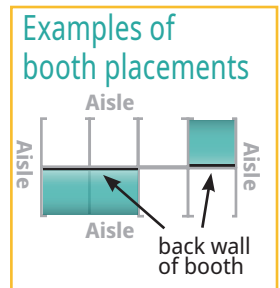

Single Aisle Booth

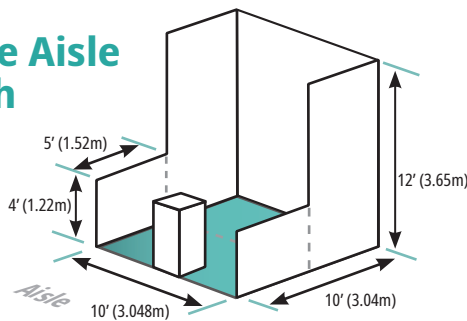

Multiple Aisle Booths

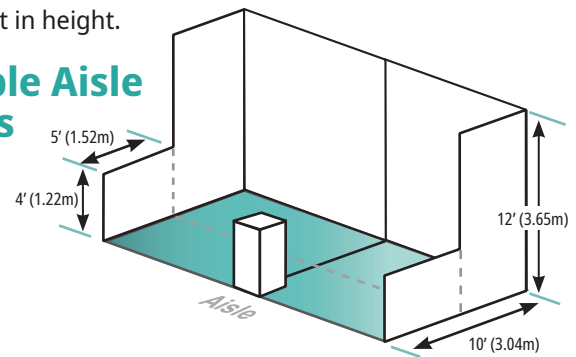

B. Peninsula - 2 Booths

Two or more booths including adjacent corner booths must conform to the requirements of a peninsula booth.

- Peninsula booths are two combined booths at the ends of non-numbered aisles.
- The back wall shall be centered and not exceed 10 feet in width and 12 feet in height.
- There are no side walls allowed.
- Signage in a two booth peninsula may not exceed the 12 feet in height of the back wall.

Peninsula Booth

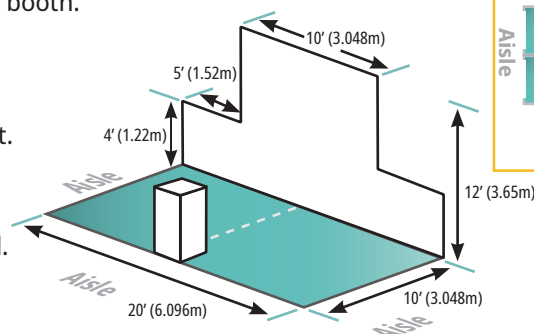

Examples of booth placements

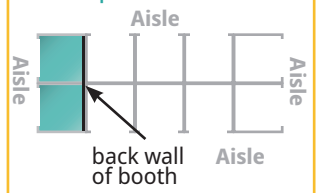

Booth Design

B. Peninsula - 4 Booths

Four booths including adjacent corner booths must conform to the requirements of a peninsula booth.

- Peninsula booths are four combined booths at the ends of non-numbered aisles.
- The back wall shall be centered and not exceed 20 feet in width and 12 feet in height.
- Signage and booth decor in a peninsula booth may not exceed 12 feet in height.

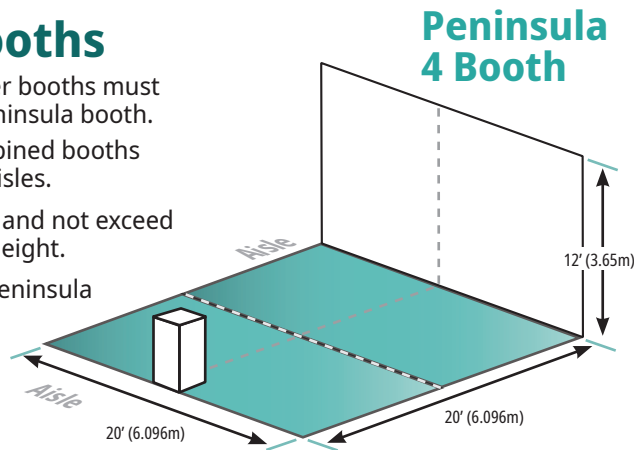

Example of peninsula 4 booth placement

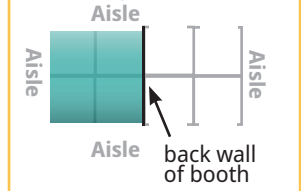

C. Island Display

Island booths are completely surrounded by aisle space.

- Island display structures in island areas may deviate from the normal regulations on size and placement. Please provide a booth design layout for PDC approval by **January 17, 2027**.
- Signs exceeding 16 feet in height must have prior written approval by the Pacific Dental Conference.

Island Display

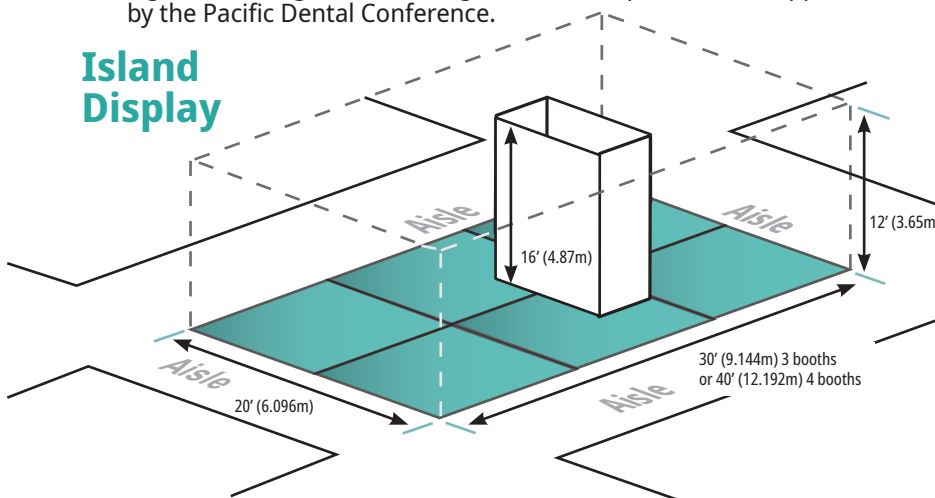

Examples of booth placements

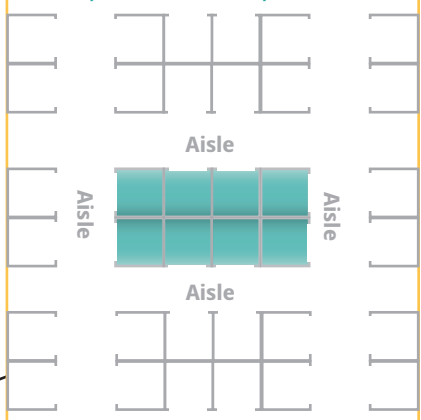

Hanging Signs, Banners and Trusses

- Hanging signs, banners or trusses are **not** permitted on single aisle booths or corner booths.
- The top of any hanging signs or banners or trusses is 20 feet.
- For all other booths, all signs, banners and trusses must be approved in writing by the Pacific Dental Conference by **January 17, 2027**.
- The Pacific Dental Conference reserves the right to remove all signs, banners and trusses which are deemed to be objectionable by the Pacific Dental Conference or its designates.
- Arrangements must be made in advance, through the Vancouver Convention Centre, at a cost to the exhibitor. For information on the Sign/Banner Installation & Dismantle Request Form see our website on December 1, 2026.

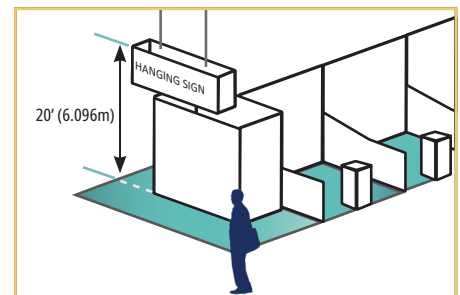

Exhibitor Rules of Conduct

Booth Guidelines and Exhibitor Rules

The booth guidelines and exhibitor rules of conduct are presented to create fairness for all exhibitors. In the case of a major violation of any of the guidelines the Pacific Dental Conference reserves the right to close any exhibit.

As each exhibitor is entitled to a reasonable sight line from an aisle regardless of the size of the exhibit, no background may be placed to obstruct, block, or interfere with the visibility of an adjacent booth.

The exhibitor must keep the exhibit open and staffed during exhibit hours and shall not close until after **5:30pm March 5, 2027**.

Exhibitors shall be responsible for all damage to structures and furnishings which may be caused by their representatives.

Any action which the Pacific Dental Conference considers to be an annoyance to other exhibitors will not be permitted.

The use of live or recorded audio and video displays is permitted but must not be heard by adjoining booths.

The use of drones, hoverboards or any other self-balancing scooters is not permitted in the Exhibit Hall or any meeting space in the Vancouver Convention Centre.

Samples

Distribution of samples is permitted provided it does not interfere with an adjoining exhibitor.

All exhibitor activities must be restricted to the booth space rented. **Distribution of materials and samples outside of the booth is prohibited.**

Aisles must not be obstructed at any time. If a display attracts a large number of attendees, including line ups, the exhibitor must still provide clear aisle space, and contain line ups within the booth space.

Food and Beverages

Distribution of food and beverages not manufactured or related to the activities of the exhibitor are to be purchased through the Vancouver Convention Centre.

Acceptability of Exhibitors

The Pacific Dental Conference reserves the right to review all applications for booth space to determine their suitability.

Badge Policy

Lost or stolen badges must be reported to the registration desk. Only employees/contractors of the exhibiting company may have an exhibitor's badge. The misuse of exhibitors' badges could result in expulsion of the violator from the Exhibit Hall and convention without obligation by the Pacific Dental Conference.

Child Policy

Only children twelve years and over are allowed in the Exhibit Hall and must have a paid 'Exhibits Only' badge. Disruptive behaviour will result in the revocation of attendance privileges. Infants are permitted in the Exhibit Hall in a 'snugglie' only and strollers are strictly prohibited.

Smoking

The Vancouver Convention Centre is a non-smoking venue. Smoking is prohibited at all times throughout the facility including Move In and Move Out hours.

Subletting

No exhibitor shall, without the written permission of the Pacific Dental Conference, assign, sublet, or apportion the whole or any part of the space allotted. **Only the registered exhibiting company will be listed in the PDC App.**

Compliance With Regulations

The Pacific Dental Conference reserves the right to take such action and to make such changes as are considered necessary to the efficient and proper conduct of the exhibition. The Pacific Dental Conference reserves the right to restrict exhibits, which, because of noise or any other reason, become objectionable.

Non-compliance with regulations, as determined by the Pacific Dental Conference, can result in the removal of the offending exhibitor or the closing of his exhibit, without indemnity, and the Pacific Dental Conference is released from any kind and all claims for damage which might result in consequence thereof.

Exhibitor Rules of Conduct

Fire Department Regulations

The Vancouver Fire Department and Vancouver Convention Centre regulations are vigorously enforced. Fire hose cabinets must be left accessible and in full view at all times. All aisles must be kept clear and all exits to fire stairs unobstructed.

All drapes, table coverings, display materials, and papers used for decorating purposes must be flame-proof and subject to inspection by the Vancouver Fire Department and the Vancouver Convention Centre. No flammable fluids or substances may be used or shown in booths. Dust covers, if required, must be supplied by the exhibitor and must be flame-proof.

Insurance

The Pacific Dental Conference will take every reasonable precaution to prevent loss to exhibitors' goods, but under no circumstances will the Pacific Dental Conference or the Vancouver Convention Centre assume any responsibility for loss or damage to exhibitors' goods which might ensue from any cause in connection with transfer, installation, maintenance, or removal of exhibits. The Pacific Dental Conference, and the Vancouver Convention Centre are not responsible in any way for goods while on exhibit or in storage.

Exhibitors are strongly advised to maintain normal precautionary measures to protect their display material and equipment and to cover their property and person with suitable insurance. It is suggested that exhibitors carry a minimum of \$2 million general liability insurance and all-risk legal liability insurance.

General

All matters not covered in these regulations are subject to the decision and control of the Pacific Dental Conference, notwithstanding anything in the application for space or contained in these regulations. The Pacific Dental Conference expressly reserves the right to change the dates of the Conference; to transfer the Conference to another building if, for any reason, the Vancouver Convention Centre should not be available; to change the floor plan or alter the location and/or alter the size of the exhibitor's space.

Limitation of Liability

In case the premises are destroyed, or in case any circumstances whatsoever, which shall make it impossible for the Pacific Dental Conference to permit any exhibitor or exhibitors to occupy the premises, the exhibitor shall pay for space only for the period the space was or could have been occupied by such exhibit or exhibitors. The Pacific Dental Conference is released from liability of any kind and all claims for damage which might arise in consequence thereof.

In the event that for any reason the exhibition is not held as proposed, the Pacific Dental Conference, on refunding all monies received from an exhibitor or exhibitors, shall be released from all claims for damage.

Variations

No verbal arrangement or any variation of this Agreement or its conditions is binding on the Pacific Dental Conference unless confirmed to the Lessee, in writing, by the Pacific Dental Conference.

*Application for approval of any variation from standard booth design must be submitted in writing to the Pacific Dental Conference by **January 17, 2027**. Exhibitors will be notified as to the acceptability of the variance.*

The Pacific Dental Conference reserves the right to approve or make changes to any exhibit, which may be deemed detrimental to the Pacific Dental Conference.

Governing Law

Each and all of the provisions of these Conditions and Rules shall be deemed an integral part of the contract for exhibit space, with the same force and effect as if set forth in said contract. The law governing the interpretation and implementation of this contract is the law prevailing from time to time in the province of BC.

Exhibitor Compliance Requirements

To ensure the health and safety of Canadians, companies exhibiting and selling devices or products at the Pacific Dental Conference must have a current Canadian Establishment and/or Product Licence issued by Health Canada. On our website, www.pacificdentalconference.com, go to the Exhibitors tab and click on the FAQ's to find out what you need to know.

Pacific Dental Conference reserves the right to cancel any exhibit booth request that does not comply with Health Canada requirements. Information

on guidelines for Establishment and Product Licenses can be found on Health Canada's website at www.hc-sc.gc.ca under Drug & Health Products, Compliance & Enforcement, Medical Devices. Verification of Medical Device Licence compliance will be required prior to set-up at the conference. Details will be sent out to exhibitors who have been allocated booth space for PDC 2027.

Event Rules and Regulations

Exhibitor Events

No company shall be allowed to host or sponsor an event, program, or continuing education course during the Pacific Dental Conference without the written permission of the Pacific Dental Conference. This rule applies to exhibitors as well as companies not participating on the Pacific Dental Conference exhibit floor. Company hosted events, programs or CE courses must begin no earlier than 5:30pm on **Thursday, March 4 and Friday, March 5**. If you have any questions, **do not hesitate to contact us at exhibits@pdconf.com** or 604-736-3781.

PDC Graphic Reproductions

Companies wishing to use the Pacific Dental Conference logo or likeness or any of the elements of the conference branding must seek approval prior to distribution. A sample of the promotional media can be sent to exhibits@pdconf.com and explain where, how and to whom it will be distributed. PDC will also be able to supply logo artwork where approval has been granted. Distribution of the logo, likeness or elements of the conference branding without approval may result in forfeiture of the companies opportunity to exhibit in the future.

Booth Representative Registration

Exhibit Hall open March 4–5

Registration of Booth Representatives

Exhibitor On-site Exhibitor Badge printing will be at the Vancouver Convention Centre - West Building at the following times:

Wednesday, March 3	7:00am to 7:00pm
Thursday, March 4	7:00am to 6:00pm
Friday, March 5	7:00am to 6:00pm



Booth Representative Credentials

Each exhibiting company may register up to six booth representatives per 10' x 10' booth at no charge. Additional booth representatives may be registered for a fee of **\$30 per person***. Badges are non-transferable.

If a previously registered booth representative is unable to attend, name substitutions may be made through your online registration portal.

Official conference badges must be worn at all times while attending the Conference.

Important: Exhibitor badges provide access to the Exhibit Hall only. Booth representatives are not permitted to attend educational sessions or earn Continuing Education (CE) credits. Individuals wishing to attend lectures must register as Conference Attendees. For attendee registration information, please visit the Pacific Dental Conference website under the **For Attendees** section.

*** All fees are subject to 5% GST.**

Safety Vests

Due to WorkSafeBC regulations, all exhibitors are required to wear WorkSafeBC approved high-visibility vests at all times during move-in and move-out periods. Booth staff setting up can either bring their own vest or purchase at onsite vending machines located at the West Loading Bays and by the East Exhibit Hall Entrance.



Booth Supply Orders

Carpeting is mandatory

Carpeting is not included in your booth space. Floor covering in your booth is mandatory and must cover the entire booth space. Arrangements can be made through Levy Show Services by filling out a Carpet Rental Request Form.*

Telecommunications, Internet

Exhibitors requiring computer data lines must make their own installation and billing arrangements with the Vancouver Convention Centre. Arrangements can be made by filling out a Telecommunications Request Form or the Internet Request Form.*

The PDC provides conference attendees complimentary WiFi throughout the East and West facility. Exhibitors do have access to this, however for a reliable connection for the purpose of conducting business, we highly recommend making arrangements through the Vancouver Convention Centre using the applicable forms.

Lead Retrieval Scanners

For bar coded lead retrieval scanners, arrangements must be made by submitting a Request Form.*

Parking

For parking information see the General Parking Information PDF and for Reserve Parking (available only in the East Building) see the Reserve Parking for East Building Request Form.*

Sign and Banner Installation

Arrangements must be made in advance, through the Vancouver Convention Centre, at a cost to the exhibitor. Information on the costs and specifications will be found on the Sign/Banner Installation & Dismantle Request Form.* All orders must be received at least twenty one (21) days prior to the conference.

Booth Cleaning

For vacuuming of the booth between the show sessions, arrangements must be made with Vancouver Convention Centre by submitting the Booth Vacuuming and Shampooing Request Form.*

Lighting and Electrical Requirements

Special illumination and electrical requirements for booths must be arranged, in advance, through the Vancouver Convention Centre, at a cost to the exhibitor.

Information on the cost of connections and special wiring, as well as other available equipment, will be found on the Electrical Services Request Form.* All orders must be received at least fourteen (14) days prior to the conference to avoid a surcharge. Electrical outlets will not be provided.

All electrical wiring, installation and connections shall be made by designated approved personnel at the exhibitor's expense. Electrical current in the Exhibit Hall is 120/208 volts, 60 cycles. Illuminated display booths and electrical equipment on display in the Vancouver Convention Centre must conform to the rules and regulations of the Canadian Standards Association.

****Show service forms and online ordering
will be available on the website,
as of December 1, 2026 at
www.pacificdentalconference.com***



Health & Safety Protocols & Procedures



We will communicate to you through email newsletters of changes as they happen which will affect you and your company. Please ensure that your email contact information is up-to-date for your main contact and alternative contact person, in your exhibitor account.

Move In / Move Out Procedures

Move In

The Vancouver Convention Centre - West Building (VCC) is a unique facility, located in the busy core of downtown Vancouver. Exhibitor and freight entry to the VCC is via the Waterfront Truck Route on Waterfront Road. We recommend working with the PDC's official carrier **Cross Connect Customs & Event Logistics Inc.** to simplify your entire shipping process.

The Move In schedule floor plan, showing the earliest possible Move In time for each exhibitor, will be available online at www.pacificdentalconference.com/movein on **October 6, 2026**, once booth locations have been assigned.

Vehicles are not allowed to park in the loading areas, bays or on the truck route at any time. All vehicle access to the Vancouver Convention Centre loading dock for move in/out is controlled and scheduled by Voyage Control and must be booked in advance using the online system. Please see below for full information.

For erecting, servicing, storing, dismantling, and repackaging of exhibit booths arrangements must be made through **Levy Show Service Inc.** This would also include fork lift services, general labour and specialized equipment. Please see page 14 for additional details.

The VCC does not provide any exhibitor storage on-site. We suggest you contact **Levy Show Service Inc.** to handle your on-site Move In/Move Out and storage services.

Move Out

Booths must not be dismantled or removed prior to **5:30pm, Friday March 5, 2027**. All exhibits must be dismantled and removed from the exhibit floor no later than **3:00pm Saturday**. All freight remaining on the show floor past this time, will be "rescued" by the official carrier of the PDC, **Cross Connect Customs & Event Logistics Inc.** unless prior arrangements have been made. Once the show ends, the aisle carpets will be removed and exhibitor crates returned. Vehicles will be given access as soon as this is completed and exhibitors are ready to move. Make outbound shipping arrangement with **Cross Connect Customs & Event Logistics Inc. as they will be on-site and can assist with after-hours shipping.** Exhibit materials stranded in the Exhibit Hall past the move-out deadline will be removed by **Cross Connect** at the exhibitor's expense.

Vancouver Convention Centre – Voyage Control

SAVE TIME & MONEY with the Logistics Management system powered by Voyage Control

The Pacific Dental Conference, in collaboration with the Vancouver Convention Centre, is committed to providing a seamless experience for all vehicles and freight accessing the Convention Centre. With the complimentary online reservation service, **Voyage Control**, exhibitors can reserve a time slot that is convenient for move-in/out at the facility loading dock. This streamlined system will save exhibitors time and money, as there is no longer any waiting in line for access to the loading dock. Exhibitors will have a dedicated time allocated to access and unload their freight. This system will also contribute in reducing our carbon footprint by eliminating idle waiting time of vehicles.

Please ensure this information is forwarded to the person responsible for booking your freight to the 2026 Pacific Dental Conference.

Working with the PDC's Preferred Suppliers simplifies the delivery process for exhibitors as they will manage the Voyage Control reservation system for you. All vehicle access to the Vancouver Convention Centre loading dock for move in will be controlled and scheduled by Voyage Control, and must be booked in advance using the online system. Starting **Tuesday, February 16, 2027 at 8am PST**, exhibitors will be able to book a time to access the Vancouver Convention Centre West Loading Dock with their vehicle.

If exhibitors are bringing multiple vehicles or making multiple trips, they must complete one booking **for each vehicle/trip**.

Each vehicle has a limited time allocation at the loading dock. Once you have finished unloading please **remove your vehicle**. Time allocations will be monitored and drivers must comply to avoid being towed.

Specific booking instructions with the link to the system and specific User Type and Booking Code will be forwarded to all exhibitors by **Thursday, February 11, 2027**.

Please be aware that any vehicle arriving without a booking will be subject to delays.



Hand Carried Items:

Exhibitors bringing in smaller items which do not require vehicle access to the loading dock, do **NOT** need to book through Voyage Control. Instead they may enter through the Main Entrance or Parking Level with materials in hand or handcart directly to their booth and begin set up during their assigned Move In time.

Move In / Move Out Procedures

Preferred Suppliers to the Pacific Dental Conference

Cross Connect Customs & Event Logistics Inc. Contact Info

Advance Warehouse, Carrier, Customs Broker

Cross Connect Customs & Event Logistics
Remy Perrot - Vice President, Sales
E-Mail: remyp@crossconnectcl.com
Tel: +1 (604) 505-5717

Exhibit Transportation and Customs Brokerage

In order to facilitate the most efficient and cost effective transport and customs brokerage service possible, **Cross Connect Customs & Event Logistics Inc.** has been appointed as the Preferred Transport Carrier & Customs Broker for the Pacific Dental Conference.

The Pacific Dental Conference has registered with the Canada Border Services Agency (CBSA) and has designated **Cross Connect Customs & Event Logistics Inc.** as the official provider of customs services. The Exhibit Hall has received "Border-to-Show" status and Cross Connect will facilitate customs procedures based on the exhibitor needs for entry into Canada. Their staff will contact exhibitors and provide instructions prior to the conference as well as will be on-site for the entire event.

***Show service forms and online ordering will be available on the website, as of December 1, 2026 at www.pacificdentalconference.com.**

Advance Receiving Warehouse

Cross Connect Customs & Event Logistics Inc. is providing a cost effective Advance Receiving Warehouse location. Advance Warehouse receiving window is **January 23-February 24, 2027**. Cross Connect has early delivery privileges, working with them will ensure your materials are delivered to the Vancouver Convention Centre prior to regular exhibitor move-in times.

Advance Receiving Warehouse Address

Exhibitor Name, Booth #
PACIFIC DENTAL CONFERENCE
c /o ABF / Cross Connect
27450 55th Avenue (Langley Township)
Langley, BC Canada V4W 3Y1

Shipping Materials for Arrival on Day-Of-Show

The Vancouver Convention Centre has limited storage space and cannot accept goods prior to the scheduled Move In time. Any deliveries arriving before their Move In time will be turned away. It is the exhibitor's responsibility to ensure that their designated carrier arrives at the Vancouver Convention Centre at the day and time scheduled. The schedule of Move In times will be forwarded with your booth assignment. All shipments for the Pacific Dental Conference must be sent pre-paid including duty, brokerage and all taxes. Please ensure Exhibitor Name on the label corresponds with the company name on the Exhibit Account.

Cross Connect Customs & Event Logistics Inc. has early delivery privileges they will ensure your materials are delivered direct to the Vancouver Convention Centre prior to regular move-in times.

Please consign all direct-to-show site shipments as follows:

Exhibitor Name, Booth #
PACIFIC DENTAL CONFERENCE
Vancouver Convention Centre – West Building
1055 Canada Place
Vancouver, BC Canada V6C 0C3

NOTE: Shipping charges to either the advance warehouse or direct-to-show site DO NOT include Material Handling. See the Material Handling/Drayage section for descriptions and options of this service. (See page 14)

Move In / Move Out Procedures

Preferred Suppliers to the Pacific Dental Conference

Levy Show Services Contact Info

Show Services

Levy Show Service Inc.
150-11188 Featherstone Way
Richmond, BC, V6W 1K9
Tel: 604-277-1726
Fax: 604-277-1736

Advance Receiving Warehouse

Shipping display material in advance will ensure that exhibitor materials will be in their booths by the time installation begins. Shipments may be sent to the advance warehouse up to thirty (30) days before the **Tuesday March 2, 2027** move in day. All shipments must be received at the warehouse five (5) working days prior to exhibitor Move In or the exhibitor may be subject to additional handling charges. Please complete the Levy Show Service Inc. Material Handling Order Form.*

Please ensure Exhibitor Name on the label corresponds with the company name on account.

Advance Receiving Warehouse

COMPANY NAME & BOOTH #
PACIFIC DENTAL CONFERENCE
Aerostream c/o Levy Show Service Inc.
18391 McCartney Way
Richmond, BC. V6W 0A1

Material Handling/Drayage

To arrange for material handling at show site, exhibitors must complete and submit the Material Handling Order Form* to **Levy Show Service Inc.**

Advance Receiving Includes:

- Receiving freight at the advance warehouse and storage for up to thirty (30) days
- Cartage charges from the advance warehouse to the show (Advance Receiving rate)
- All on-site receiving services

On-site Receiving Includes:

- Receiving and signing of exhibitor's pre-paid shipment at designated Move In time
- Unloading and delivering shipment to exhibitor's booth
- Removing and storing empty crates
- Returning empty crates to exhibitor's booth following the close of the show
- Loading onto the exhibitor's designated outbound carrier

It is the responsibility of the exhibitor to ensure that his designated carrier arrives at the conference centre at the appropriate time and date for both Move In and Move Out. Material Handling/Drayage does NOT include any freight forwarding or post show shipping.

***Show service forms and online ordering will be available on the website, as of December 1, 2026 at www.pacificdentalconference.com.**



Take advantage of the special hotel rates available only to the Pacific Dental Conference participants at the hotels listed here. Reservations can be made directly with these hotels by phoning or by clicking the links found in the **Hotel Information section** of the PDC website www.pacificdentalconference.com. Rates are subject to room availability.

Conference Hotels

PDC Exhibit Hall open March 4-5

The hotels listed below offer exclusive rates for Pacific Dental Conference participants. Reservations can be made directly with these hotels by calling the reservation numbers provided. The details can also be found in the hotel section of the Pacific Dental Conference website www.pacificdentalconference.com

- ① Fairmont Pacific Rim Hotel
- ② Pan Pacific Vancouver Hotel
- ③ Fairmont Waterfront Hotel
- ⑤ Pinnacle Hotel Vancouver Harbourfront
- ⑥ Fairmont Hotel Vancouver
- ⑦ Hyatt Regency Vancouver

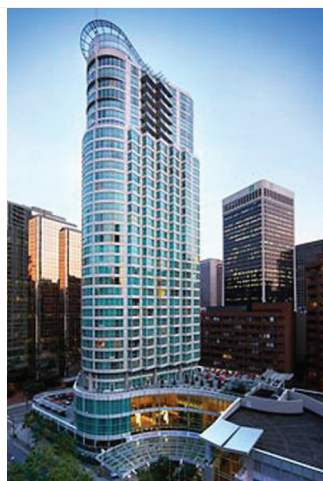

HUGE Thanks to our 2026 Exhibitors

123Dentist
ABELDent Inc.
Academy for Sports Dentistry
Academy of General Dentistry
Acteon
ADA CPA Inc.
A-dec Inc.
Adin Dental Implants
Adit
Air Techniques
Akitu One
Align Technology
AMD Medicom
Andau Medical
Ansell
Arborlea
Argen Canada
Atop Dental Canada Inc
Attridge Group
AVARI Medical
BC Dental Study Club
BC Oral Cancer Prevention Program
BCDHA
Beautifi Solutions Inc.
Belmont / Takara Company Canada Ltd.
BiLumix
BioGaia Probiotics Canada Inc.
BioHorizons Canada
BITES Institute
Blue & Green Inc.
BMO
Brasseler Canada
British Columbia College of Oral Health Professionals
British Columbia Dental Association
BTL Medical Technologies
Canadian Armed Forces
Canadian Dental Hygienists Association
Canadian Society for Disability and Oral Health
CareCru Incorporated

Carestream Dental
CDA Alliance
CDABC
CDSPI Advisory Services Inc.
Cerum Ortho
City Care Dental
Claronav Dental
ClearDent
Clearly Aligned
Clinical Research Dental Supplies & Services
Clixeen Enterprises Inc.
Clover
Colgate-Palmolive Canada
Community Antimicrobial Stewardship,
BC Centre for Disease Control
Connect the Doc
Corus Orthodontists
Crest + Oral-B
Curion Dental
D2D HealthCo.
Dandy
DCI Edge
Dens 'N Dente Healthcare
Dental Brands
Dental Canada INSTRUMENTATION
Dental Industry Association of Canada
Dental Savings Club
Dental Technicians Association of BC
Dental Tribune America
Dentalcorp
dentalree.com International Inc.
Dentsply Sirona
Denturist Association of British Columbia
Designs for Vision, Inc.
DEXIS
DiaDent Group International
Diagnocat
Directa USA
DMCL Chartered Professional Accountants
Dr. Marketing Inc.

Drake Financial Ltd.
EDI Digital Dentistry
Embrosin Medical Technologies Inc.
emilypay
EMS Dental
Endo/Tech
Envista
exocad
Experior Financial
FDI - World Dental Congress
First Edition BLS Training & AED
First Nations Health Authority
Flight Dental Systems
Forbes IT Solutions
G7technologies
Galderma
GARFIELD REFINING
Garrison Dental
GC America
Glidewell Dental
Global Surgical Corporation
Go Lease It Inc.
GOLDEN BRIDGE INTERNATIONAL
COMMERCE LTD.
Haleon Canada
HANSAmEd Limited
Hatch Group Inc.
Health Canada
Heaps & Doyle Practice Solutions Inc.
Henry Schein Canada
Henry Schein Canada, Inc.
Henry Schein One
Hesira Med Inc (HMI)
Hiossen Implant Canada Inc.
HiTeck Medical Instruments
HuFriedyGroup
iFinance Canada
Indigenous Dental Association of Canada
Intiveo
Ivoclar Vivadent, Inc.



****Companies highlighted in Purple were supporters of the PDC through sponsorship or advertising in 2026**

HUGE Thanks to our 2026 Exhibitors

Journées dentaires internationales
du Québec

K & C Precious Metals

KaVo

K-Dental

Kerr

Kulzer LLC

Kuraray Noritake Dental

LENOX INS

Lips Inc.

LISTERINE

LOGIC DENTAL AI

LumaDent, Inc.

Lumimons Pro

Luuna Scrubs

Madaisky Pollock LLP

Mansouri Enterprises Inc.

Markson Dental System

Martin Henry CPAs

MaxAssist

maxill Inc.

MBC Brokerage Ltd.

medcorp construction inc.

MediaNV

Medline Sinclair

MegaGen Canada Inc.

Merck

Microcopy

Miele Limited

Mint Ops

Museum Dental Refining

My Friend Toothy

National Dental Innovations

National Dosimetry Services

Nicola Wealth

Nobel Biocare

NSK America

Ocean Ceramics

OPTIK MEDIC

Oral Biopsy Service

Oral Health Academy

Oral Science

Orasoptic

Orbital Support Systems, Inc.
Orthodontic Supply of Canada (OSC)

Pacific Blue Cross

Pacific Oral Health Society

Pacific Training Institute for

Facial Aesthetics & Therapeutics

Panthera Dental

Paradise Dental Technologies

Passion Dental Group

Patient NEWS Dental Marketing

Patterson Dental

PaySpyre Financial Inc.

Peters Wealth Management

& Insurance Solutions

Philips Electronics Ltd.

Planmeca

Practices Made Perfect Corporation

Premier Dental Products Company

Professional Practice Sales

Professional Sales Associates Inc.

Protec Dental

Provincial Dental Project -

BC Children's Hospital

Purtzki Johansen & Associates

Q-Optics

Quest Products LLC

RAJ HANS INC Chartered

Professional Accountants

Ray America

Redl Cabinetry Inc.

Relief Buddy Inc.

Renaissance Cosmetic Arts Ltd.

RGP Dental Inc.

Richards Buell Sutton LLP

ROI Corporation

Sable Industries Inc.

Safco Dental Supply Canada

SciCan / Coltene

Scotiabank

SDI (North America) Inc.

Septodont

SHINING 3D

Shofu

Simpli Boards

SNAP ON OPTICS

Solventum

South Arm Technology Services

Sowingo

SprintRay

Strathcona Health Society

Straumann

Sunstar Americas Inc.

Supermax Healthcare Canada

SurgiTel

SYNCA

TD

Temps On Tap

The Elite Practice

The Royal Bank of Canada

The Surgical Room

Thompson Okanagan Dental Society

Tier Three Brokerage, Ltd.

Tokuyama Dental America, Inc.

Toothbrush Caddy

TPC Financial Group Ltd.

Tracker

TravelVAX

TREC Dental Foundation

Tri Hawk

UBC Faculty of Dentistry

Ultralight Optics

Univet Loupes North America

Valued Professional Products Ltd.

Vancity denture guy lab ltd.

Vancouver and District Dental Society

Vantechs

Vatech Canada

Voco Canada Inc.

W&H Impex Inc.

Water Pik Inc.

Weave

Western Handpiece Repair

ZAD Design

ZimVie

Zoll

****Companies highlighted in Purple were supporters of the PDC through sponsorship or advertising in 2026**

Sponsorship & Advertising Opportunities

We are exploring sponsorship and advertising opportunities. As these become available we will notify our registered exhibitors by email and e-newsletters with the details of these new opportunities. If you have ideas of new ways we can work together to promote your company, please contact us to discuss at 604-736-3781 or exhibits@pdconf.com

Pacific Dental Conference Vancouver Canada

PDC Exhibit Hall open March 4-5

2027

Pacific Dental Conference

Contact Information

We can be reached at:

Pacific Dental Conference (office)

420 - 4400 Dominion Street

Burnaby, BC V5G 4G3

Telephone: 604-736-3781

Email us at: exhibits@pdconf.com

website: www.pacificdentalconference.com

Future Conference Dates

March 4-6, 2027

March 9-11, 2028